

Understanding Eye Pattern Measurements

Introduction

The growth of high-speed Internet has driven data-transmission technology to fully commercialize on 10 Gbps data rates for use in metro and access segments of the next generation network. A key enabling component in the physical layer is the transceiver module, which enables vital transmit and receive operations at the end of each fiber optic link. Transceiver modules, such as the XFP/SFP/SFP+ configurations, are governed by Multi-Source Agreements that ensure consistency between suppliers with requirements for eye mask measurements. These eye mask definitions specify transmitter output performance in terms of normalized amplitude and time in such a way to ensure far-end receivers can consistently tell the difference between one and zero levels in the presence of timing noise and jitter.

The measurement instrument that verifies eye mask compliance is commonly referred to as a high-speed sampling oscilloscope. This instrument class measures samples of the input signal to form an eye diagram that can be used for analysis of the signal's noise, jitter, and eye mask compliance. The ability to accumulate and display samples supports statistical analysis techniques for assessing the quality of the digital signal, but does not detect protocol or logic problems. The quality of digital signals is simple to see with an eye diagram: Bit-Error-Rate (BER) degrades with eye closure. Figure 1 shows two Anritsu instruments that feature the latest in eye pattern analysis for manufacturing and field applications.



Figure 1. Low-cost, high performance, eye pattern analyzers are essential tools for verifying that eye mask compliance tests of 10 Gbps transmitter outputs adhere to industry standards. Shown are new instruments from Anritsu, the MP2100A BERTWave™ and the MP1026B Bit Master™.

This application note reviews basic eye diagram definitions and terminologies, and presents several typical examples of measurement applications. Its objective is to present practical information that will help engineers conduct 10 Gbps eye pattern measurements using the eye pattern analyzer.

Eye Pattern Fundamentals

An eye diagram is a useful tool for understanding signal impairments in the physical layer of high-speed digital data systems, verifying transmitter output compliance, and revealing the amplitude and time distortion elements that degrade the BER for diagnostic purposes. By taking high-bandwidth instantaneous samples of a high-speed digital signal, an eye diagram is the sum of samples from superimposing the 1's, 0's, and corresponding transition measurements. What results is an image that reveals the "eye" of the eye diagram, as shown in Figure 2.

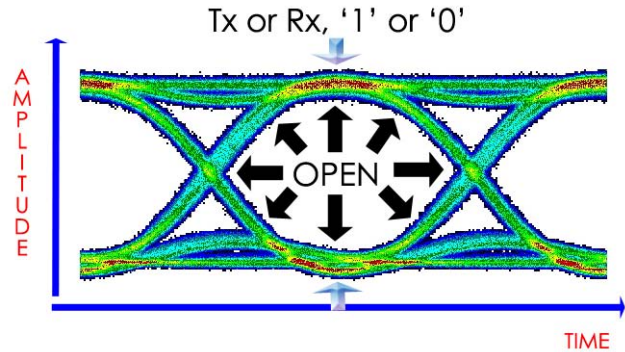

Figure 2. An eye diagram results from superimposing the "0"s and "1"s of a high-speed digital data stream.

For easy viewing, the time axis in Figure 2 is normalized for 2 bits, with the 1 bit "eye opening" in the center of the display and 1/2 bit to the left and right of the center eye for capturing rise/fall-time transitions. Note that any data bits in the rise/fall transitions of the digital signal that infringe on the center of the eye opening may cause data errors and will be discussed later in the application note.

Although the eye pattern in Figure 2 depicts some noise and jitter, other forthcoming examples will show data system waveforms with considerably more noise and a center eye that closes more significantly. Generally speaking, the more open the eye is (indicated by the arrows in the diagram), the lower the likelihood that the receiver in the transmission system will mistake a logical 1 bit for a logical 0 bit, or vice versa. These logic decisions require a certain margin of signal differential between the 0 and the 1 level. Noise, both amplitude and time jitter, reduces that margin and is logically depicted in Figure 2 as some closure of the eye opening. The ratio of bits that have errors, compared to the overall bits, is called BER.

The eye diagram does not show protocol or logic problems. It does, however, allow the engineer to more easily view signal impairments in the physical layer in terms of amplitude and time distortion.

Eye Pattern Measurement Technology

Sampling oscilloscope technology provides the frequency bandwidth (typically 25 GHz) necessary to capture the full data characteristics of 10 Gbps data waveforms. Modern high-bandwidth sampling oscilloscopes use a low sampling rate (typically under-sampling on the order of 100 ksps) to generate a two-dimensional X versus Y database that statistically represents the time and amplitude of a digital signal. As more samples are accumulated, the database grows in the third dimension (plot density), which represents the number of pixels that fall in the same X-Y location on the display (Figure 3).

The significance of accumulating measurements for analysis is evident in the side-by-side screen captures in Figure 3. In the left screen capture (8,000 samples), the histogram plot located below the left crossing point indicates that the normal distribution of samples in the window contains only 38 samples. In contrast, the right screen capture (10 million samples) contains nearly 6,000 samples in its histogram.

Note that the time histogram of the crossing point data (below the eye diagram) exhibits more of a normal distribution in the right screen capture. Histograms of other amplitude parameters are also possible. The mean, standard deviation and peak-to-peak (p-p) readouts and histograms become more statistically relevant with more samples.

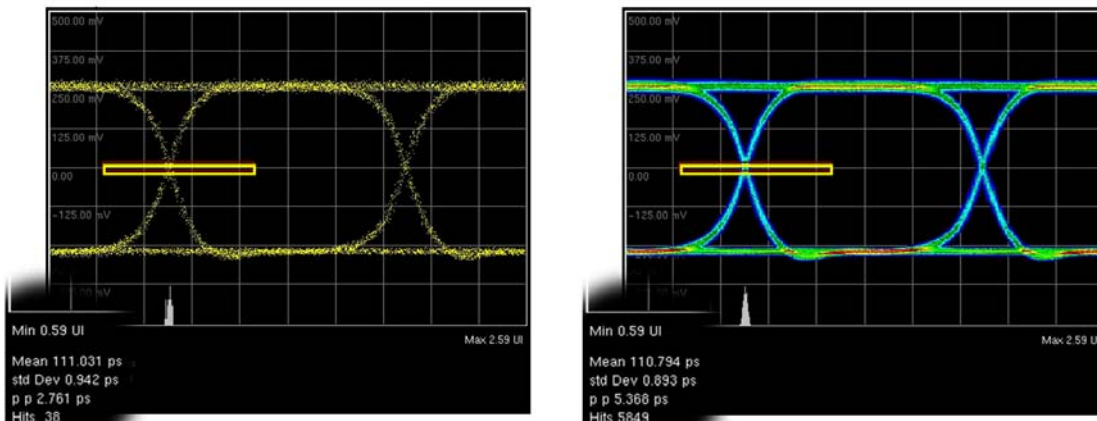

Figure 3. Shown here are two displays from a sampling oscilloscope. The left screen shows 8,000 whereas the right screen shows 10 million samples. The additional data enables the more precise measurement of noise and jitter in high-speed digital signals.

Typical Setup for Eye Pattern Measurements

For the purposes of this application note, eye pattern measurements require a pulse pattern generator and eye pattern analyzer. One example configuration uses the Anritsu MP1800A Signal Quality Analyzer (SQA) to generate the 10 Gbps data streams and the Anritsu MP1026B Bit Master to measure the eye pattern (Figure 4).

The MP1800A SQA is a measuring instrument that provides BER and quality analysis of digital signals from 100 Mbps up to 12.5 Gbps and beyond. It provides both a Pulse Pattern Generator (PPG) and Error Detector (ED) in a single instrument, as well as for multi-channel support for parallel testing. It is ideal for research and development of high-speed logic, ICs, digital systems, FTTx, and PON.

Anritsu's MP1026B Bit Master is a self-contained, battery-operated, eye pattern analyzer with powerful diagnostic and software test routines for eye mask compliance testing. It is well suited for use with the high-speed data rates of modern communications systems.

Anritsu also offers the MP2100A BERTWave instrument, a manufacturing solution with integrated BERT plus EYE/Pulse Scope capabilities. With this single instrument, all testing capabilities are available to thoroughly characterize transceiver modules, including eye pattern measurements.

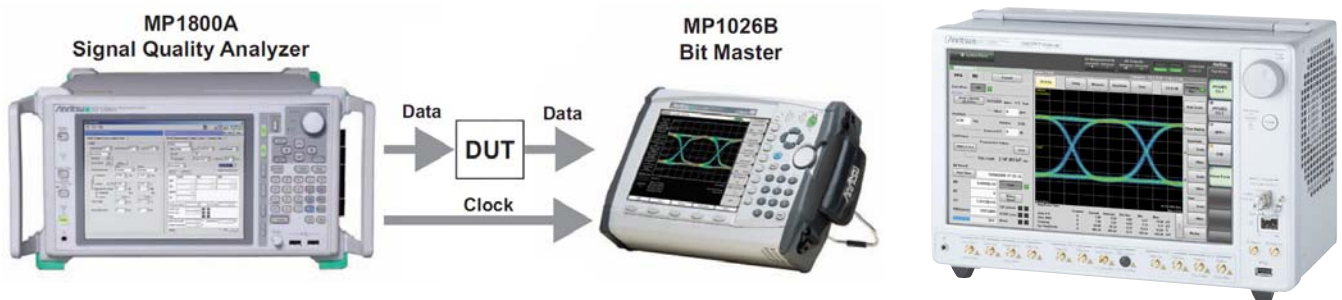

Figure 4. Powerful data generators and sampling technology comes with this pair of data communications instruments on the left: the Anritsu MP1800A Signal Quality Analyzer and MP1026B Bit Master Eye Pattern Analyzer. On the right is the new MP2100A BERTWave instrument with integrated pulse generator and eye pattern analyzer.

Introduction to Histograms

Histograms are used to statistically analyze time and amplitude data of eye diagrams, offering important computational information when observing impairments in high-speed digital signals. For this reason, it is a worthwhile detour to highlight the key statistical definitions that formulate the basis of eye pattern measurements.

Mean and standard deviation are two important aspects of the time and amplitude distortion in a high-speed digital data stream. As a brief refresher of the definition of these terms, consider the normal distribution shown in Figure 5. According to this graphic:

- Mean is the sum of data values divided by the number of values
- Standard Deviation, two sigma, is $\pm 1\sigma$, ± 34 percent (or 68 percent) of mean
- Standard Deviation, six sigma, is $\pm 3\sigma$, ± 49.85 percent (or 99.7 percent) of mean

The mean of a data set is simply the arithmetic average of the values in the set. It is obtained by summing the values and dividing by the total number of values. The standard deviation is a measure of the spread of data. The 2σ (2 sigma) standard deviation is approximately 68 percent of data points within $\pm 1\sigma$ of the mean for a normal distribution. The 6σ standard deviation is approximately 99.7 percent of data points within $\pm 3\sigma$ of the mean for a normal distribution.

If many data points in a histogram are close to the mean, then the standard deviation is small. On the other hand, if many data points are far from the mean, then the standard deviation is large. When all data values are equal, the standard deviation is zero. These terms will play an important part in the upcoming amplitude and time distortion definitions.

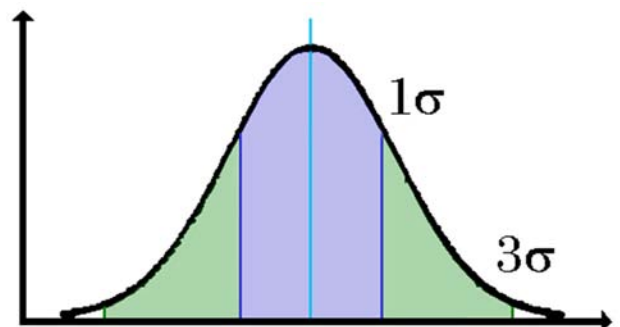

Figure 5. This graphic depicts a "normal" distribution of data.

Amplitude Definitions of Eye Patterns (Vertical Axis)

A number of terms are used to describe amplitude characteristics for eye diagrams. Amplitude distortion terms can be extracted from an eye diagram using the eye pattern analyzer, and are typically based on calculations from histogram data. These terms include:

One Level. The one level in an eye pattern is defined in Figure 6. The one levels of the time/pulse waveform in the graphic on the right are highlighted by the arrows. Note the existence of 11 and 111, as well as 00 and 000, pulse clusters. As the eye pattern in the graphic on the left is scaled, left-to-right, from 0 to 100 percent between the crossing points, the one level is calculated as the mean value of the top histogram distribution in the middle 20 percent of the eye. This middle 20 percent is also referred to as the 40 to 60 percent region and is highlighted in the scale under the eye pattern measurement. The actual computed value of the one level comes from the histogram mean value of all the data samples captured inside the middle 20 percent of the eye period.

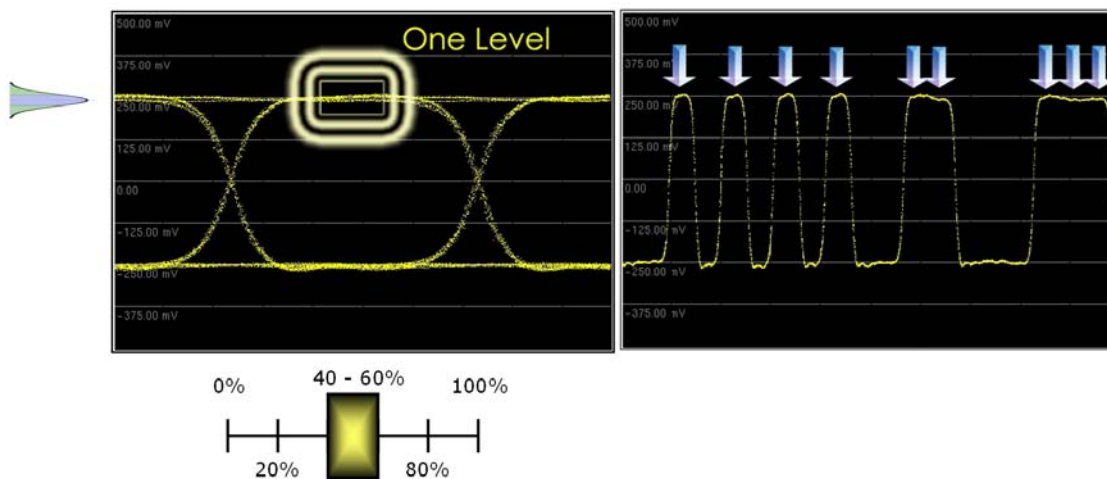

Figure 6. This graphic shows an eye pattern (left) with its associated pulse pattern versus time (right). The one level is computed from measurements made between the 40 and 60 percent region of the bit period. The histogram (upper left) shows the statistical processing of the numerical "1" level data.

Zero Level. As shown in Figure 7, the zero level is computed from the same 40 to 60 percent region of the baseline area during the eye period as the one level. Likewise, the actual computed value of the zero level comes from the histogram mean value of the data captured inside the middle 20 percent of the eye period.

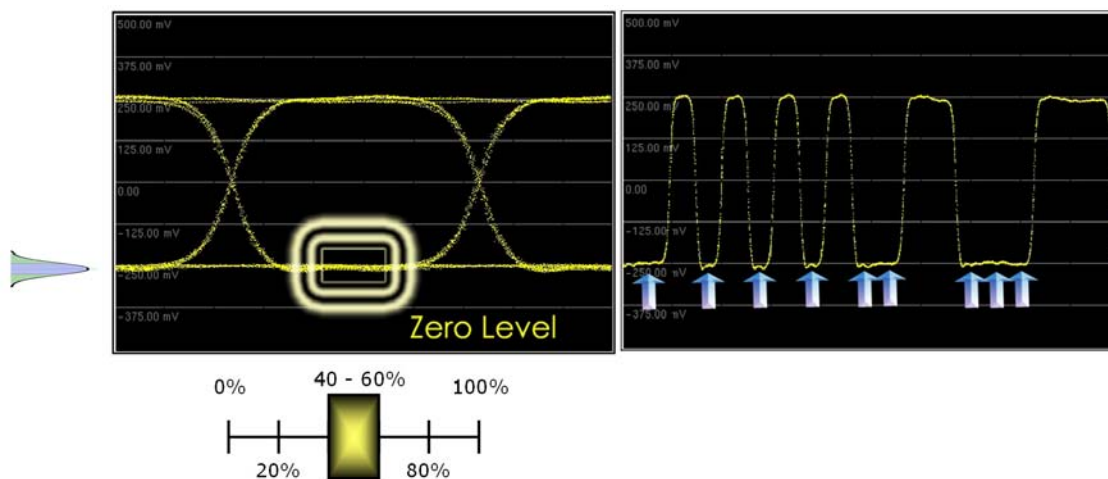

Figure 7. The zero-level value comes from the same center 40 to 60 percent region of the eye crossing points and from the mean value of the histogram data as shown on the left.

Eye Amplitude, Eye Height. The definitions for eye amplitude and eye height are shown in Figure 8. Eye amplitude is the difference between the one and zero levels. The calculation values used are the mean values of the two histograms shown, measured during the middle 20 percent region of the eye crossings. The definition for eye height is derived from computing the difference between the inner 3σ points on the inside of the histograms of the one and zero levels.

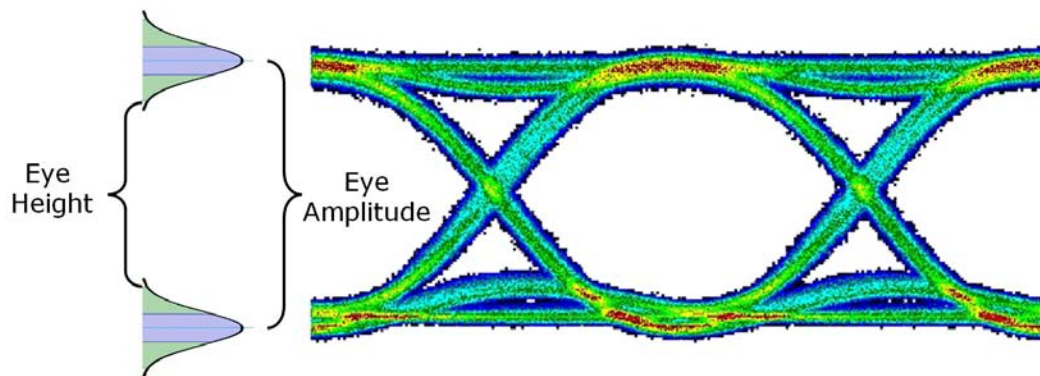

Figure 8. The data processed into the differences for eye height and amplitude comes from histogram data of the one and zero levels.

The eye amplitude and eye height definitions are important amplitude terms since the data receiver logic circuits will ultimately determine whether the data bit is a “0” or “1,” based on the eye amplitude. Furthermore, because any data bits scattered beyond the 3σ points into the open eye will indicate a possible error in the detection, the BER is dependent on the eye height.

Eye Crossing Percentage. The eye crossing percentage is a measure of the amplitude of the crossing points relative to the one and zero level. It provides a clear indication of how well the system’s data pulse symmetry is performing. Figure 9 shows how data for this parameter are detected and processed.

To determine the eye crossing percentage, the one level, zero level and crossing level must first be found using histograms as shown in the screen capture overlays in Figure 9. The crossing level is determined by taking the mean value of a thin vertical histogram window centered on the crossing point. The crossing percentage is then calculated using the following equation:

$$100 * [(crossing\ level - zero\ level)/(one\ level - zero\ level)]$$

The one- and zero-level values are measured as the mean values in the middle 20 percent of the eye. The final eye crossing percentage scale is shown on the right of Figure 9 with 0 percent at the zero level and 100 percent at the one level.

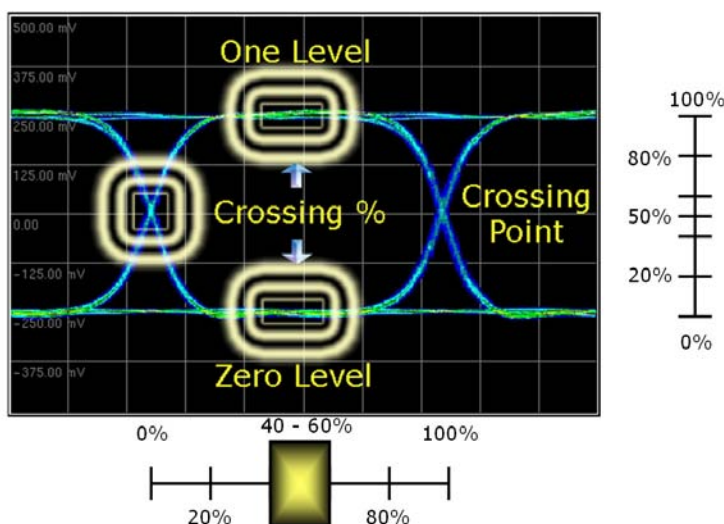

Figure 9. This display shows how the histogram data for the eye crossing parameter are gathered. It essentially tells how high the crossing points are at the left and reveals pulse-symmetry characteristics.

To help better understand this component of the amplitude distortion, consider the following examples. Figure 10 depicts six screen captures, organized into eye patterns on the left and pulse patterns on the right. By looking at what's happening to the symmetry of the 1's and 0's in the pulse pattern versus time (right column), one can more clearly understand the impact to the eye crossing percentage.

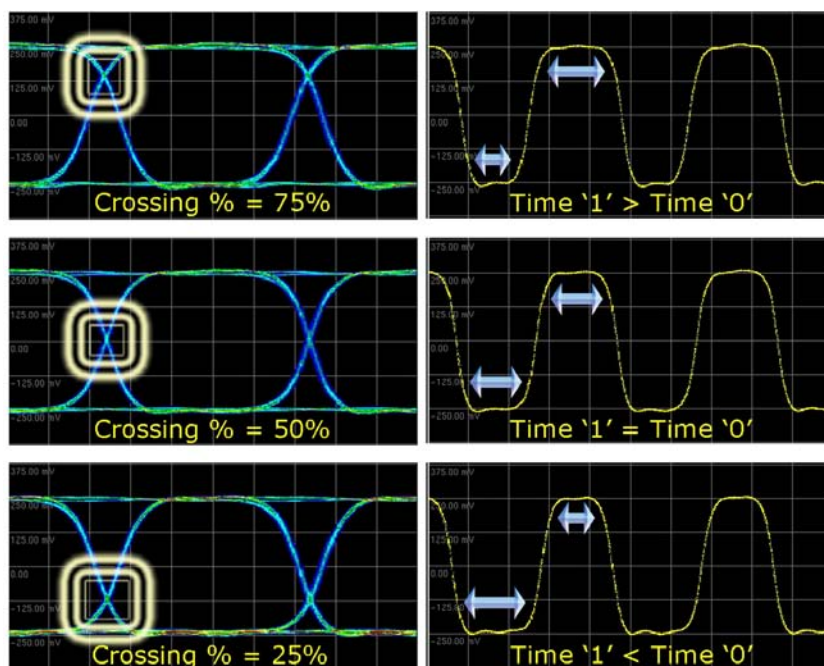

Figure 10. Three different eye pattern crossings are shown for 75, 50 and 25 percent, along with their corresponding pulse/time displays. The ideal case is crossing percentage of 50 percent. The one longer in duration than zero causes the crossing percentage to increase, as shown in the 75 percent example. In contrast, the zero longer in duration than one causes the crossing percentage to decrease, as shown in the 25 percent example.

The three rows of screen captures are further organized from top to bottom in terms of eye crossing percentage. In the top row, with a 75 percent eye crossing percentage, the time-pulse pattern for the “1” is longer in duration than the “0.” The longer time for a “1” pushes the crossing point up. The pulse pattern shows that the “0” duration is also much shorter in time than the “1.”

Eye crossing percentage is valuable for measuring amplitude distortions caused by differences in the one- and zero-level durations. It also reveals pulse symmetry problems for diagnosis. When the eye crossing symmetry value deviates from the perfect 50 percent point, the eye closes, which degrades BER.

Signal-to-Noise Ratio (SNR). The SNR is the last of the amplitude distortion terms and is defined as a ratio of the desired signal level to the level of background noise, plus any distortion. Higher SNR values are more desirable than lower SNR values (Figure 11).

To calculate SNR, eye pattern analyzer uses the following equation:

$$\frac{(\text{one level} - \text{zero level})}{(1\sigma [\text{one level}] + 1\sigma [\text{zero level}])}$$

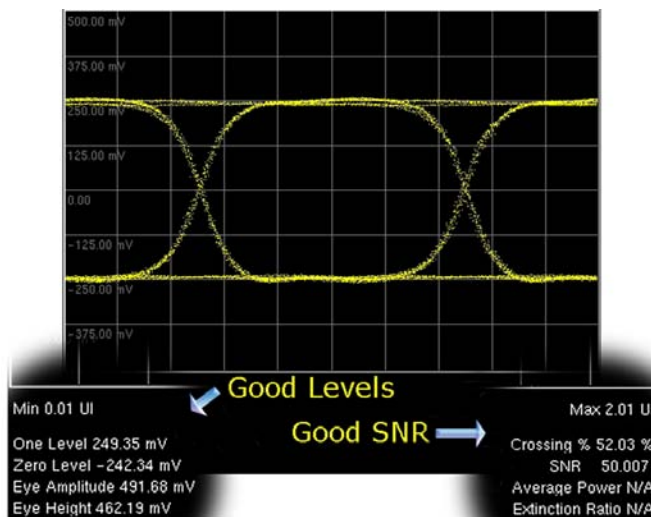

Figure 11. An example of good levels of SNR is shown in this eye pattern measurement. The background noise and distortion is much smaller than the signal, which is a desirable condition.

In Figure 11, the block of actual histogram measurement numbers on the bottom of the display indicate a high SNR value of 50 (50.007) when using an eye amplitude of nearly 500 mV (491.65). Figure 12 shows what a very poor SNR setup looks like. In this case, the signal is obscured by the background noise. Looking again at the numerical data block (lower left of the display), it can be seen that the eye amplitude is only 7 mV from the data readout. On both screen captures, it is noted that the one and zero levels are broadly distributed and largely buried in noise. In this situation, the standard deviation is large because many points are away from the mean and the eye height is very small. In other words, the receiver data detectors are going to have problems differentiating between 1's and 0's with this level of SNR.

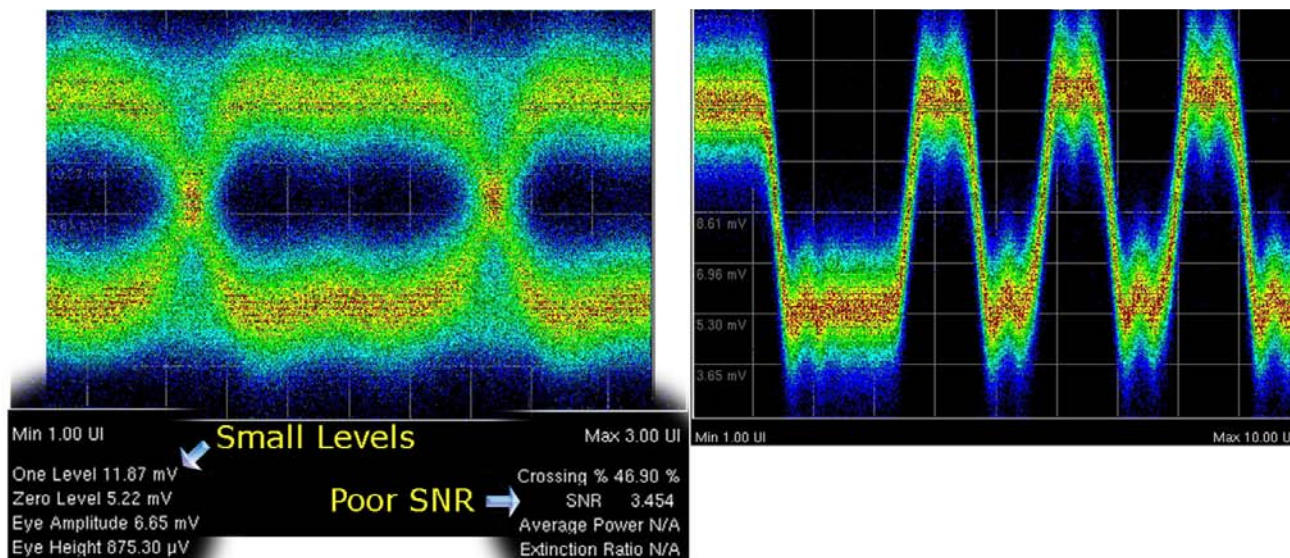

Figure 12. This system will show a rather badly degraded eye diagram due to poor SNR.

The final SNR calculation is only 3.5, as compared to 50 in the previous example. As a result, this system will need an increase in signal level or a reduction in noise in order to improve the SNR enough to conduct better eye pattern measurements. Such a noisy signal and low BER is probably hopeless as a real-life system signal.

Time Definitions for Eye Patterns (Horizontal Axis)

Like amplitude distortion terms, time distortion terms can be extracted from an eye diagram using the Anritsu Bit Master. While these parameters are commonly-known pulsed-data terms, their measurement by the Bit Master will be described mostly in terms of histograms derived from the eye pattern.

Before defining these terms, it is necessary to introduce the concept of a Unit Interval (UI). As shown in Figure 13, a UI is defined as one data bit-width, irrespective of the data rate. In a 9.8 Gbps data stream, for example, one UI is equivalent to 102 ps. For a 2.0 Gbps data stream, one UI is equivalent to 500 ps.

In Figure 13, the horizontal time axis can be displayed as picoseconds or UI, which is essentially the number of bits. Hence, one data bit-width is interchangeable with one UI. The UI is also a convenient way to specify jitter performance in some standards and data sheets. The advantage of using UI instead of actual time on the horizontal scale is therefore clear. It is a normalizing term, irrespective of the data rate, and therefore makes it easier to view eye-pattern measurements of different data rates (Figure 14).

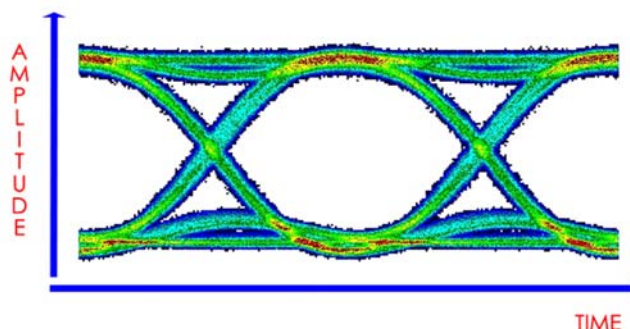

Figure 13. The UI is the time between eye crossings and is not dependent on the data rate. This terminology offers convenience in specifying jitter performance. In addition, using UI instead of time on the horizontal scale could simplify comparison of various eye diagrams at different data rates.

The screen captures in Figure 14 are arranged to show eye-pattern and pulse-pattern measurements for two different data rates. The top row consists of screen captures at 2 Gbps, while the bottom row screen captures are at 9.8 Gbps. The display column on the left shows eye-pattern measurements with the same scale (2 UI). Remember that one UI shows the whole eye centered, while there is 1/2 UI on the left and 1/2 UI on the right. The display column on the right depicts the pulse patterns versus time with a 9 UI horizontal time scale. Since the data bits are not dependent on data rates, using the UI as a horizontal time scale simplifies the analysis in some circumstances.

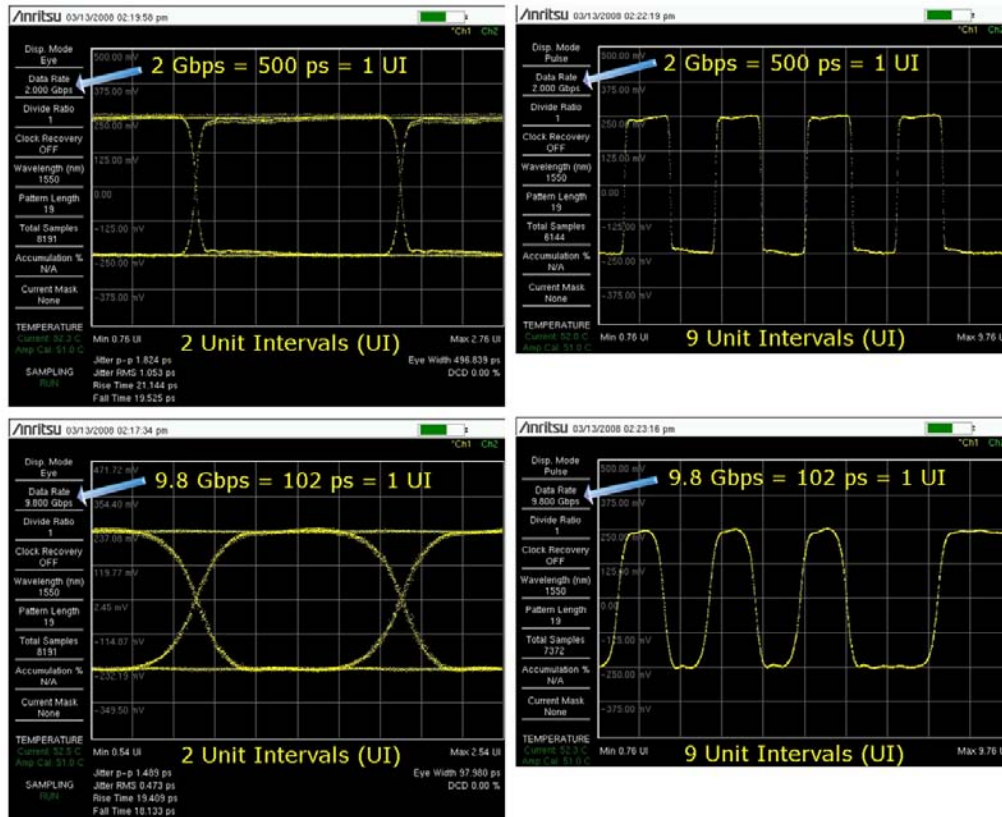

Figure 14. Two different data rates can be described by the same term, UI, even though the upper screen capture is 2 Gbps and the bottom is 9.8 Gbps.

With a basic understanding of UI in hand, the time distortion terms for horizontal eye patterns can now be more easily defined. They include:

Jitter, RMS and Peak-to-Peak. Jitter—the time deviation from the ideal timing of a data-bit event—is perhaps one of the most important topics in high-speed digital data signals. To compute jitter, the time variances of the rising and falling edges of an eye diagram at the crossing point are captured as shown in Figure 15. Fluctuations can be random and/or deterministic. The time histogram, shown below the eye pattern, is analyzed to determine the amount of jitter. The p-p jitter is defined as the full width of the histogram, meaning all data points present. RMS jitter is defined as the standard deviation of the histogram.

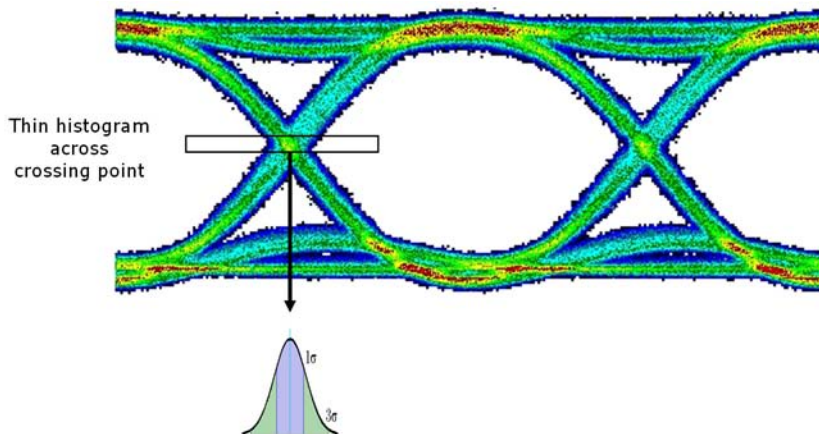

Figure 15. Jitter measurements are made with the usual histogram-gathered data, as shown at the eye crossing point.

Figure 16 shows a side-by-side comparison of a manual jitter measurement on the left to an automatic histogram measurement made using automated histogram data processing on the right

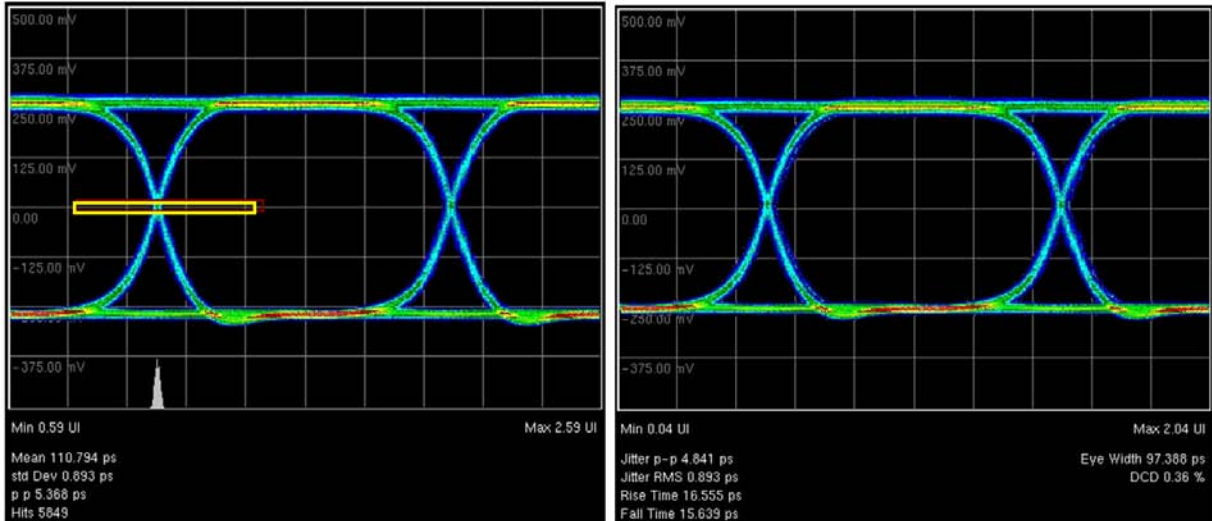

Figure 16. This actual screen capture compares an automatic and manual jitter measurement, as shown on the right and left, respectively.

By applying the thin histogram window to the crossing point on the left screen (manual) capture, the standard deviation (sigma) or RMS jitter is 0.893 ps and the p-p jitter is 5.368 ps. These values are noted in the numeric readout area under the eye-pattern measurement and are essentially the same values measured in the automatic version shown on the right. In that mode, RMS jitter is 0.893 and p-p jitter is 4.841 ps. Note that RMS jitter is sometimes referred to as standard deviation jitter.

Rise Time. Rise time is a measure of the mean transition time of the data on the upward slope of an eye diagram. To measure the 20 to 80 percent rise time, two thin horizontal histogram slices are placed at the 20 percent level (to the left of the eye crossing) and at the 80 percent level (to the right of the eye crossing), as shown in Figure 17. The rise time is then calculated using the following equation:

$$\text{Rise Time} = \text{mean (80 percent time level)} - \text{mean (20 percent time level)}$$

The 20 and 80 percent levels are determined relative to the one and zero levels. Note that the rise time results in terms of the two normal distributions under the eye diagram.

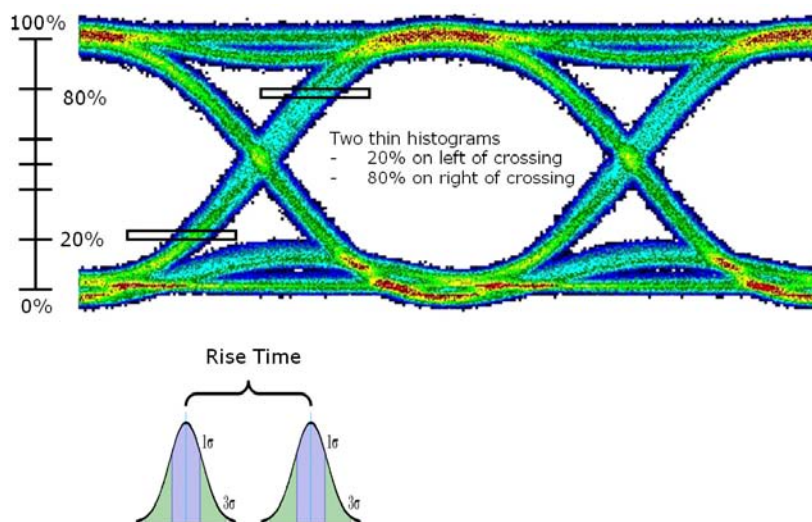

Figure 17. As shown in the lower left of the graphic, histogram data determines the time at the 20 and 80 percent points of a rising data bit. The one and zero levels determine the 0 and 100 percent points as shown on the left side.

Fall Time. Fall time is measured in a similar fashion as rise time, on the downward transition time of a data bit as shown in Figure 18. The fall time is then calculated using the following equation:

$$\text{Fall Time} = \text{mean (20 percent time level)} - \text{mean (80 percent time level)}$$

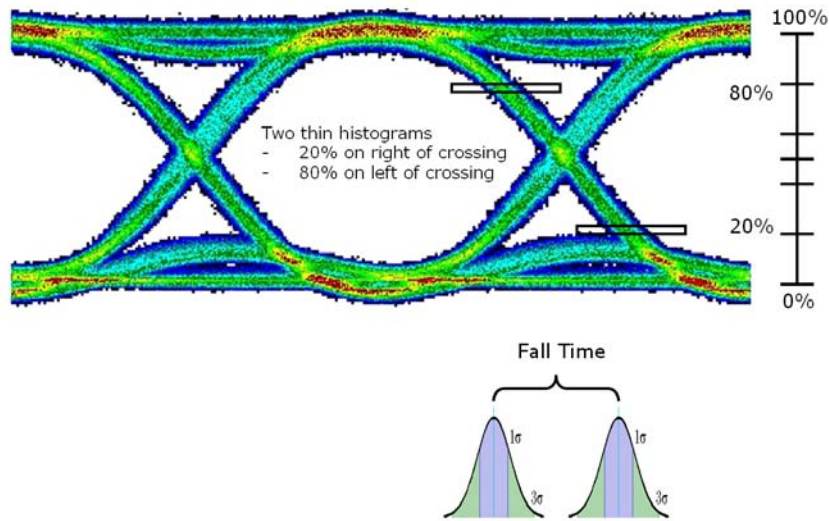

Figure 18. The fall-time transition measurement comes from the 20 and 80 percent histograms shown on the downward wave of the data bit.

Eye Width. Eye width is a measure of the horizontal opening of an eye diagram. It is calculated by first placing thin horizontal histograms at the two crossing points, as shown in Figure 19, and then using the following equation:

$$\text{Eye Width} = (\text{the left } -3\sigma \text{ crossing pt 2}) - (\text{the right } +3\sigma \text{ crossing pt 1})$$

Note that eye width is essentially the effective distance between the inner two 3σ points on the time histograms, meaning that there are virtually no samples within the clear eye space. In reality though, since the 3σ represents only 99.7 percent, there are actually 0.3 percent of samples inside the clear eye space.

Eye width can also be determined visually using the two normal distributions under the eye diagram. You simply take the left -3σ crossing pt 2 minus the right -3σ crossing pt 1. In this way, eye width is similar to eye height which is also measured between the 3σ inner points.

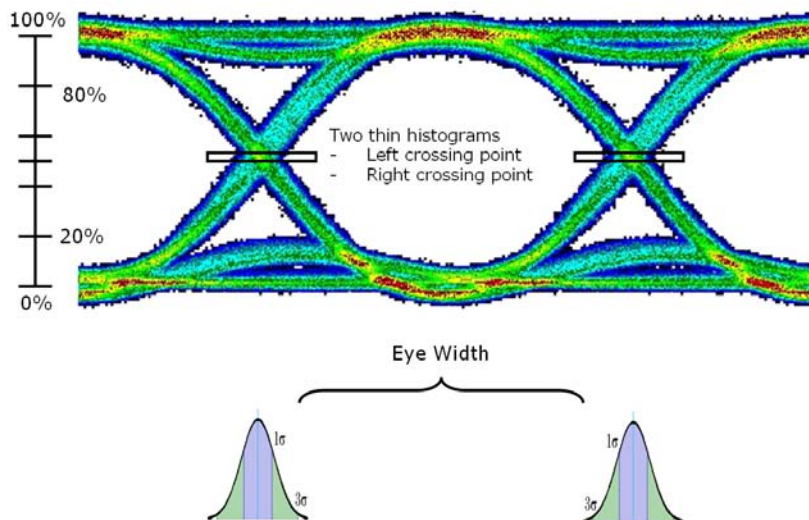

Figure 19. Eye width is the time measurement between the horizontal histogram data slices taken at the inner 3σ points.

Duty Cycle Distortion (DCD). DCD is a measure of the deviation in duty cycle from normal value and is usually caused by pulse-width deviations in the data pattern. As shown in Figure 20, it measures the time separation between the rising and falling edge at the 50 percent level of the eye diagram. To measure the DCD, the 50 percent level of the edges are calculated using the same histograms that are used in the rise-time and fall-time measurements (the center of the 20 to 80 percent measurement). The DCD is then calculated using the following equation:

$$\text{DCD} = \frac{100 \times \text{time difference between rising and falling edges @ 50 percent level}}{\text{bit period}}$$

The equation can be stated more simply as: $\text{DCD} = 100 \times (A/B)$, where A and B are the distances between the arrows in the screen capture in Figure 20.

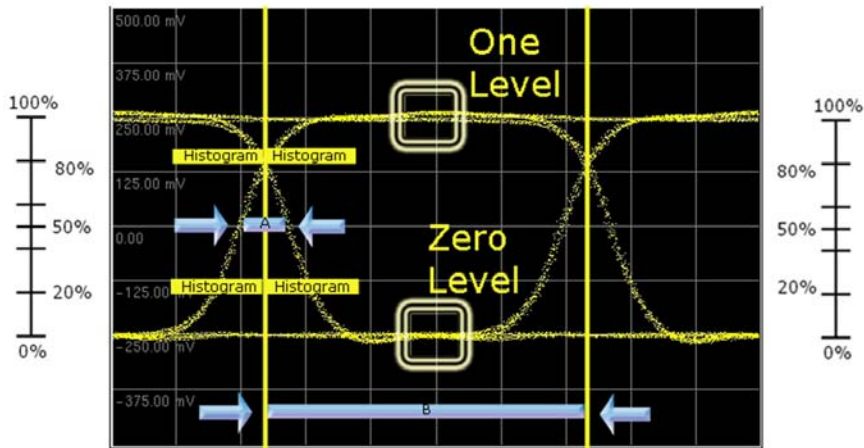

Figure 20. Data-pulse duty cycle variation, shown between the center arrows, causes bit errors when it is significant enough to close the pattern eye.

To help better understand this component of the time distortion, consider the following examples. Figure 21 depicts six screen captures, organized into eye patterns on the left and pulse patterns on the right. By looking at what's happening to the symmetry of the 1's and 0's in the pulse pattern versus time (right column), one can more clearly understand the impact to the duty cycle distortion.

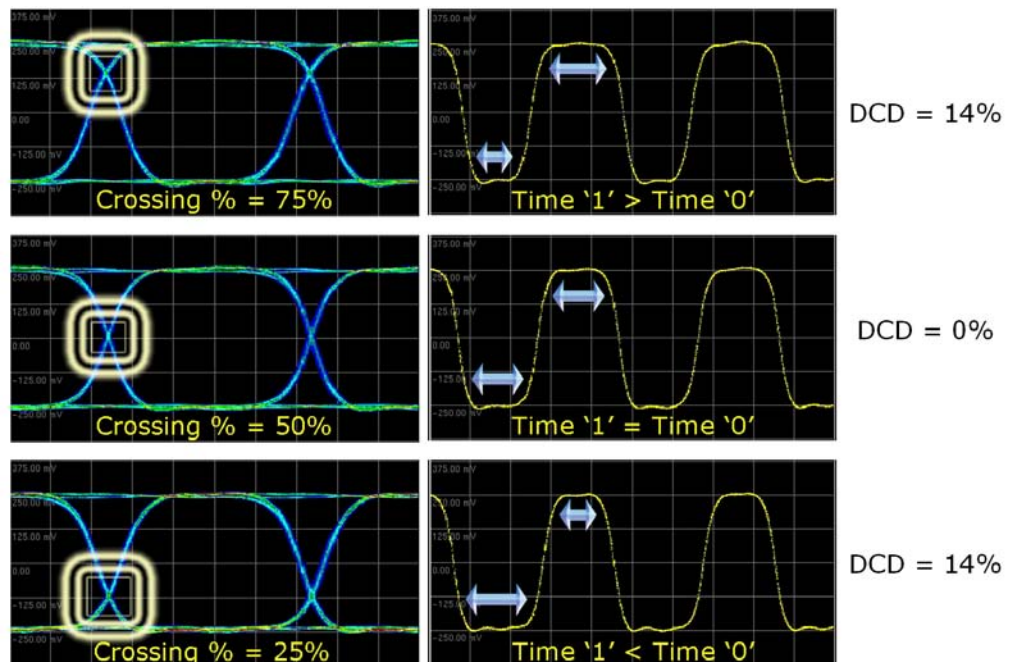

Figure 21. Data-pulse duty cycle variation, shown between the center arrows, causes bit errors when it is significant enough to close the eye. Three different eye pattern crossings are shown for 75, 50 and 25 percent, along with their corresponding pulse/time displays. The ideal case is crossing percentage of 50 percent. The one longer in duration than the zero causes the duty cycle distortion to increase, as shown in the 75 percent example. Similarly, the zero longer in duration than the one causes the duty cycle distortion to increase, as shown in the 25 percent example.

The three rows of screen captures are further organized from top to bottom in terms of eye crossing percentage. In the top row, with a 75 percent eye crossing percentage, the time-pulse pattern for the “1” is longer in duration than the “0.” The longer time for a “1” pushes the crossing point up. The pulse pattern shows that the “0” duration is also much shorter in time than the “1.”

Duty cycle distortion is valuable for measuring time distortions caused by differences in the one and zero-level durations relative to the crossing percentage. It also reveals pulse symmetry problems for diagnosis. When the eye crossing symmetry value deviates from the ideal 0 percent DCD value, the eye closes, which degrades BER.

Differential Signals and Differential Eye Pattern Measurements

Differential signals offer superior noise immunity and overall improved signal integrity, which is highly desirable in the transmission and distribution of high-speed signals. Techniques for conducting eye pattern measurements involve using trace math operations to view these signals both separately and as a pair. Examples of common and differential scenarios are highlighted in Figure 22.

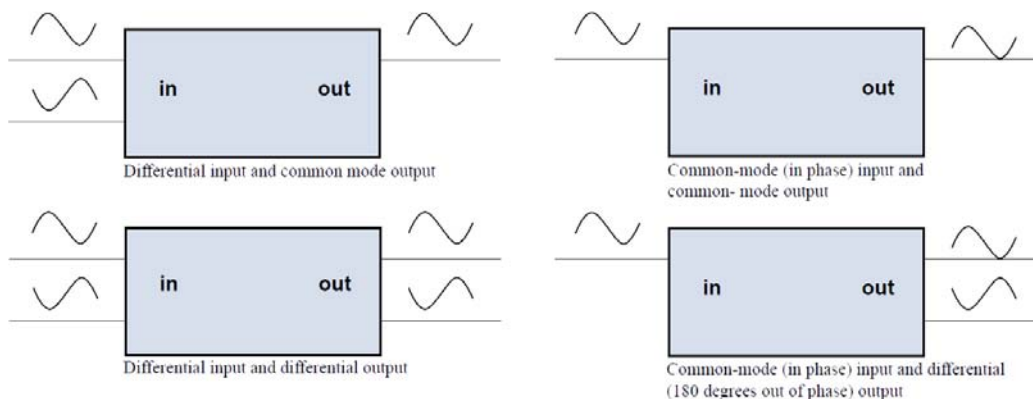

Figure 22. Examples of differential and common-mode signals are shown here. With two single-ended transmission lines treated as a pair, one can analyze eye closure in terms of common-mode and differential drive and common-mode and differential output.

Given this brief introduction, Figure 23 shows eye and pulse pattern measurements viewed separately (Ch1 and Ch2) and with trace math (Ch1 – Ch2, Ch1 + Ch2). The pulse pattern display is useful for viewing how the two separate traces align before using trace math to view the combined differential and common-mode performance of the pair.

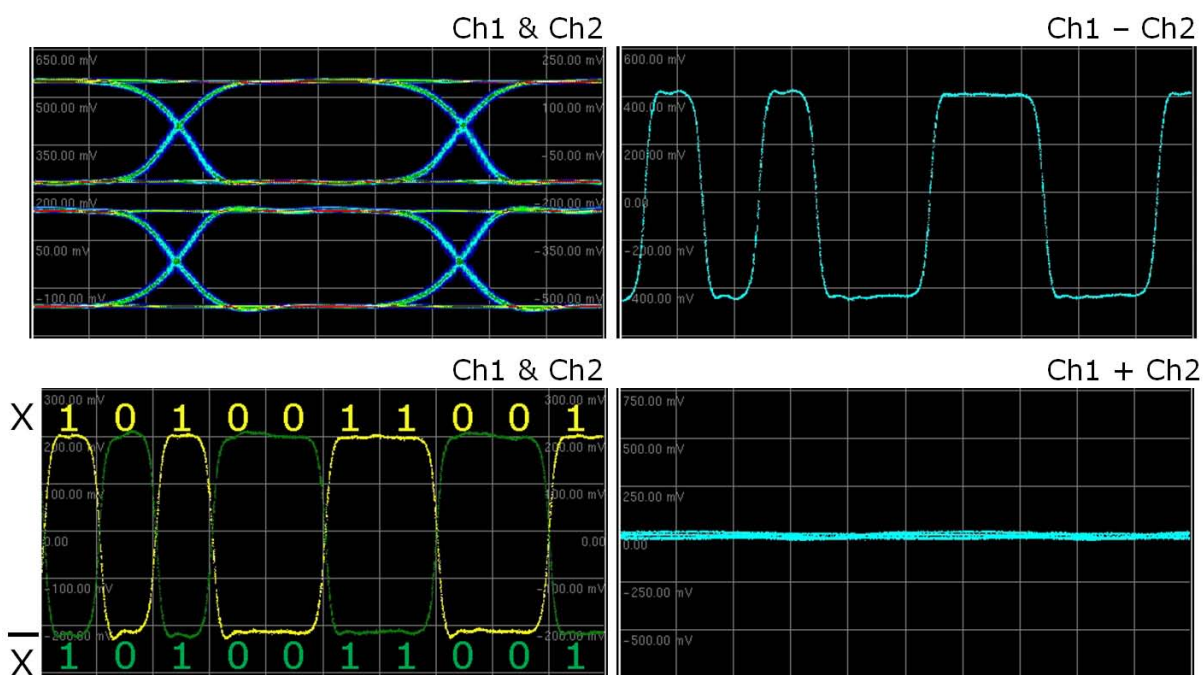

Figure 23. Examples of eye and pulse pattern measurements of differential signals are shown here. The left-hand side displays the measurements of each channel separately; whereas, trace math is applied to display differential (top) and common-mode (bottom) pulse measurements on the right-hand side. The common-mode display indicates that there is very little skew between the channels because the signal level is very small.

Trace math operations also enable the combination of the two separate channels so they can be treated as a single differential pair in terms of the eye pattern measurements. An example of a differential pair eye diagram is shown in Figure 24.

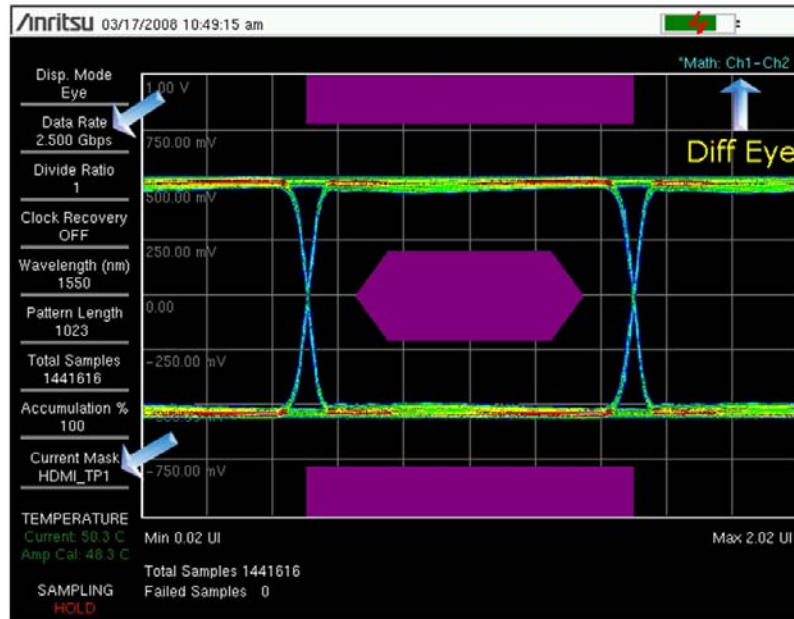

Figure 24. Mask compliance of a differential pair is possible by applying trace math operations to the two individual channels. An example for HDMI testing is shown in this figure at 2.5 Gbps.

The previous examples are ideal in that there is very little skew between the two channels. The measurements become more interesting when considering scenarios where the individual channels include a small amount of skew between Ch1 and Ch2. As can be seen in Figure 25, the overlay of two eye patterns easily reveals the difference, which is generally referred to as differential skew.

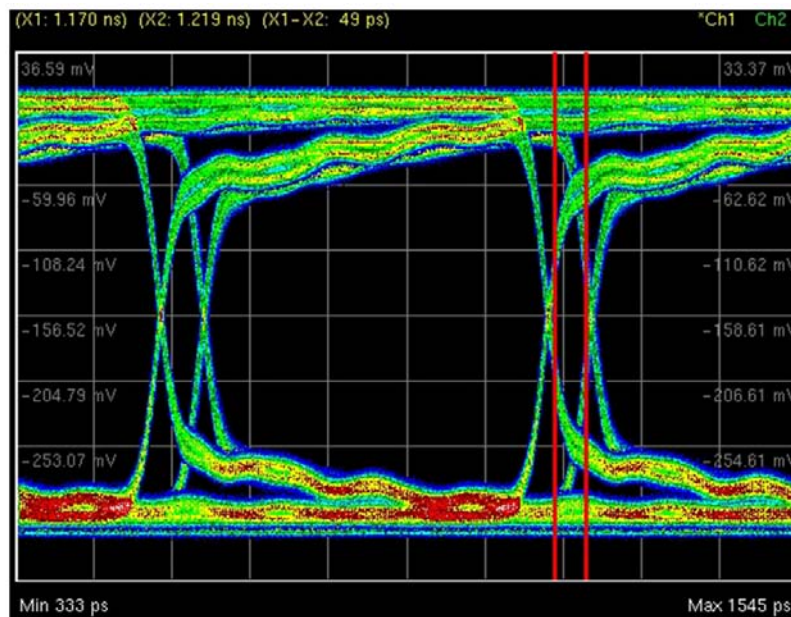

Figure 25. A measurement example of differential skew is shown here. The amount of skew is determined to be 49 ps from delta marker readout; however, this display offers a quick at-a-glance assessment of the amount of skew. This display is for quickly isolating potential problems in differential pairs that impact signal integrity.

As differential skew increases, the impairments in the differential and common-mode eye patterns become more apparent. Figure 26 shows an example for a significant amount of differential skew, but not more than the unit interval. It is useful to note that the common-mode display easily reveals differential skew for this differential class of transmission line.

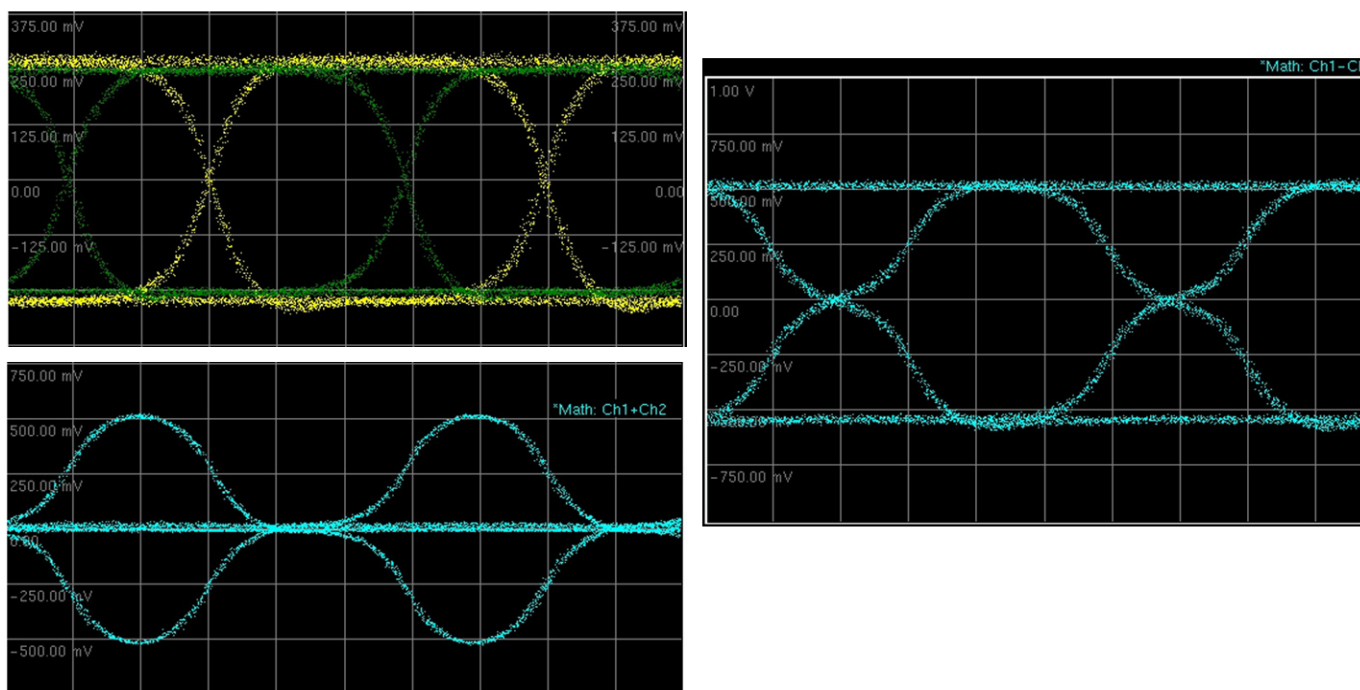

Figure 26. A measurement example with significant differential skew (but not more than one UI) is shown here. The overlay of the two channels separately is displayed in the top-left capture. The trace below shows the common-mode eye diagram (Ch1 + Ch2) while the trace on the right shows differential eye diagram (Ch1 - Ch2). Regular measurements of common-mode eye diagrams are a convenient way to detect differential skew.

As this one last example in Figure 27 demonstrates, the difficulty of observing differential skew with eye pattern measurements alone can lead to incorrect conclusions about signal integrity of the overall system. To duplicate this setup, simply set up the two channels to have offsets of one UI. The eye diagram's alignment appears acceptable until a closer look at the individual pulse patterns show the offset in UI. As a tip, differential skew greater than one UI is easier to detect with the pulse pattern measurement displays as shown in Figure 28.

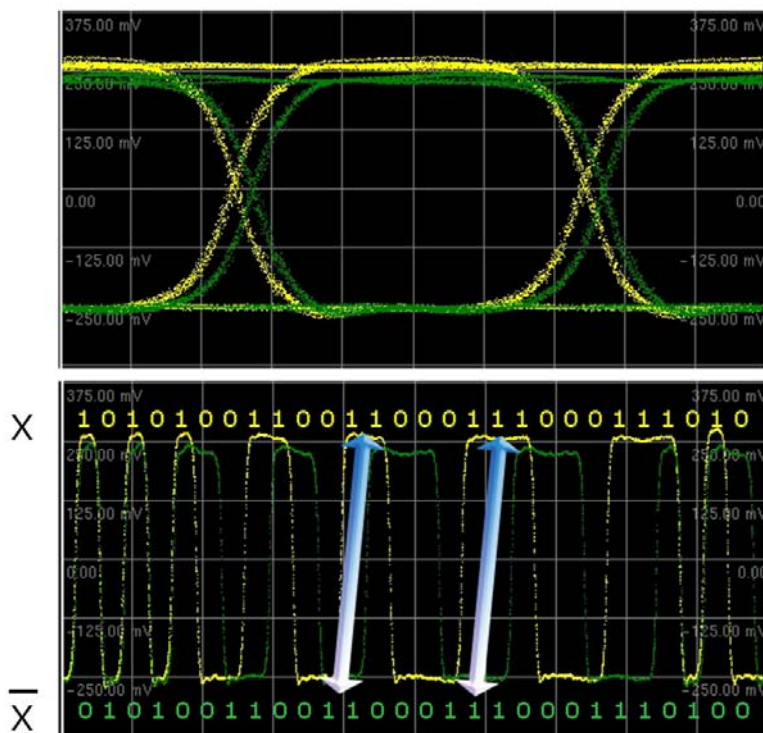
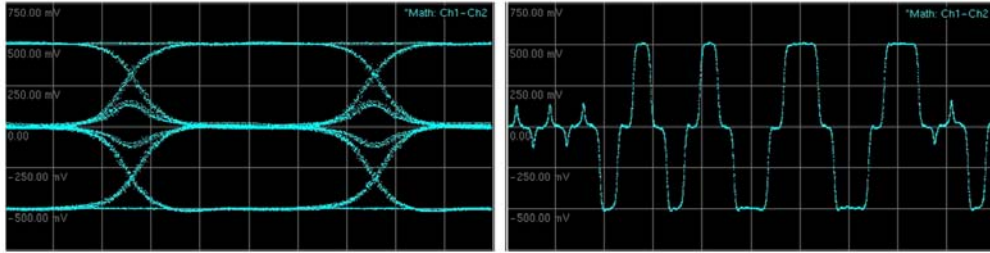

Figure 27. A measurement example with significant differential skew (greater than one UI) is shown here. The overlay of the two channels separately is displayed in the top capture and show reasonable alignment. However, a closer look at the individual pulse patterns shows the offset.

Differential (Ch1 - Ch2)



Skew (Ch1 + Ch2)

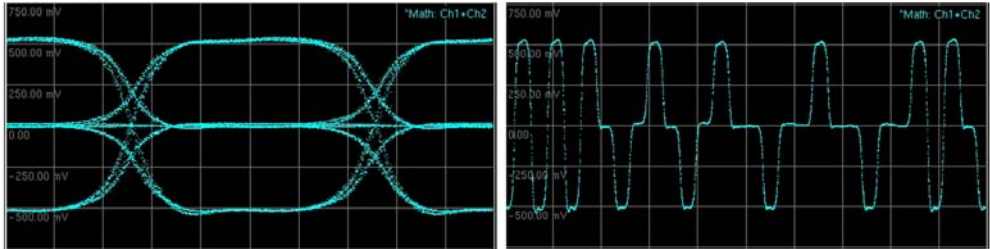

Figure 28. Applying trace math to the two individual channels offset by one UI offers easier viewing of differential and common-mode problems due to skew. The eye patterns on the left have an additional level in the middle, which is also viewable in the pulse pattern measurements on the right.

In summary, impairments are easy to see when using trace math operations even when the high-speed electrical signals are differential pairs. A powerful tool for conducting this analysis is trace math: Ch1 - Ch2 shows the differential eye pattern while Ch1 + Ch2 shows any skew present between the individual channels.

Typical Applications of Eye Pattern Diagnostics

To demonstrate the power and convenience of eye pattern diagnostics, consider the following measurement application examples of a transmission cable defect and mask compliance testing.

Transmission Cable Defect. In Figure 29, the upper right screen capture shows a Device-Under-Test (DUT) – a circuit board consisting of a transmission line with finger pressure that is causing cable impairment to the eye pattern, essentially some extra localized shunt capacitance. This extra capacitance causes pulse rise/fall times to degrade considerably and, as a result, the eye closes appreciably. An undistorted eye pattern measurement from the MP1800 SQA is shown in the upper left screen capture. The data rate is 9.8 Gbps.

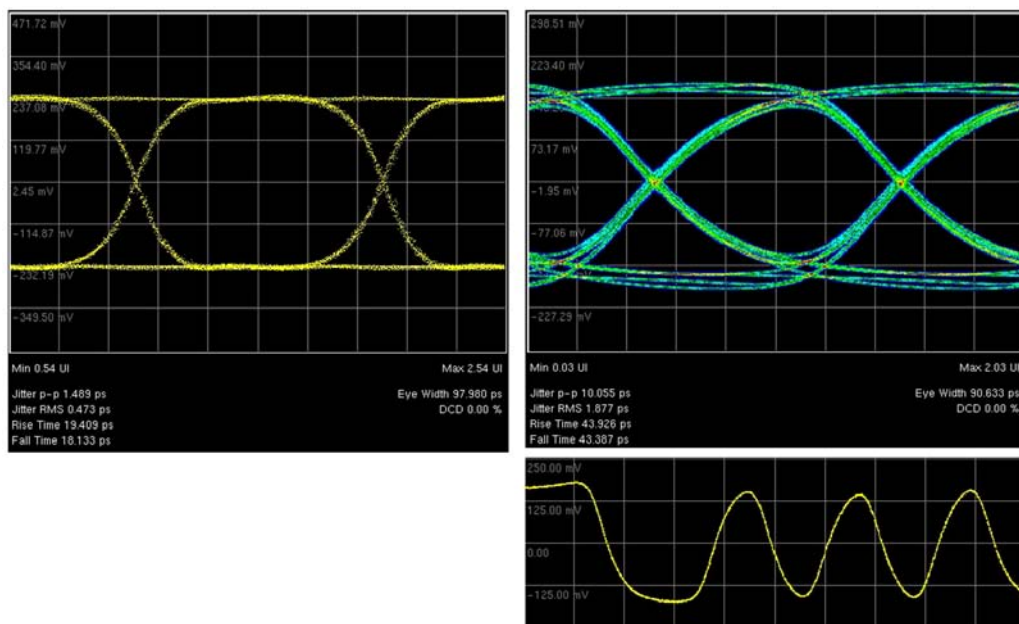

Figure 29. The left display shows a well-formed test data stream. The right eye diagram shows the effect of a transmission cable that is pinched to cause a defect, closing the eye. The video pulse pattern is shown at the bottom right.

Mask Compliance Testing. Because technology currently being employed in the Datacom/Telecom/Fibre-Channel business sector lies on the cutting edge, sophisticated measurements are mandatory. To aid in these measurements, the Anritsu Bit Master features an optional optical-to-electrical converter module.

To ensure interchangeability of standardized components like optical converters within this business sector, strict performance standards for the eye pattern diagnostic have been developed for manufacturers. These guideline measurements represent the performance limit lines for the eye pattern and are known as “masks.” Two typical test eye patterns, with their associated test-limit masks, are shown in Figure 30. Although the Bit Master display uses a full color palate, for this application note, the gray block areas (usually purple on the instrument display) represent “keep-out” areas. In order to pass the mask compliance test, the transmitter output must not have ANY samples fall within the “keep-out” regions.

The screen capture shown on the left in Figure 30 is for a 2.5 Gbps, 1550 nm eye pattern measurement using an OC48/STM16 mask. The screen capture on the right is for a 9.8 Gbps, 1310 nm eye pattern measurement using a 10GE WAN mask. Annotated/computed data in both measurement screens show zero failed samples, verifying compliance to industry standard requirements.

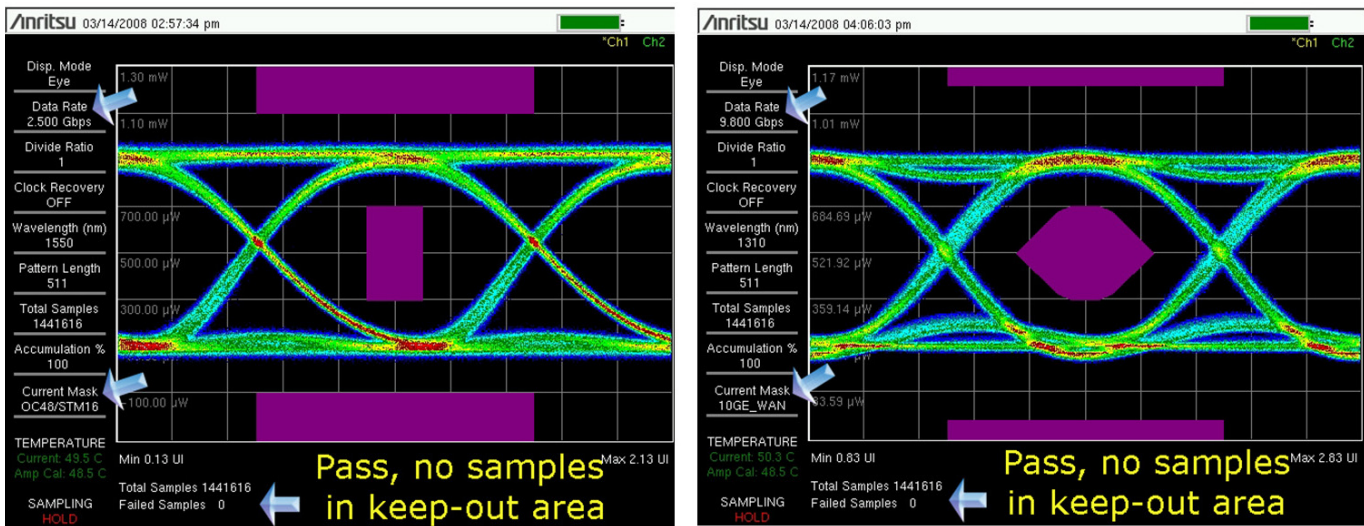

Figure 30. Typical optical data eye-pattern characteristics are shown for 2.5 Gbps on the left and 9.8 Gbps on the right. Both displays show ZERO failed samples as posted in the numeric data block on the lower left and indicated by the graphic arrows on the bottom.

Mask Margin Test. The previously described pass/fail mask compliance test scenario is useful as a go/no-go test, but manufacturing usually wants to know with how much margin is passed as a tool for monitoring and optimizing their production process. In the mask margin test shown in Figure 31, the instrumentation is expected to linearly increase the chosen mask until a failure is detected. This mask margin value is recorded and analyzed to detect trends in the production process.

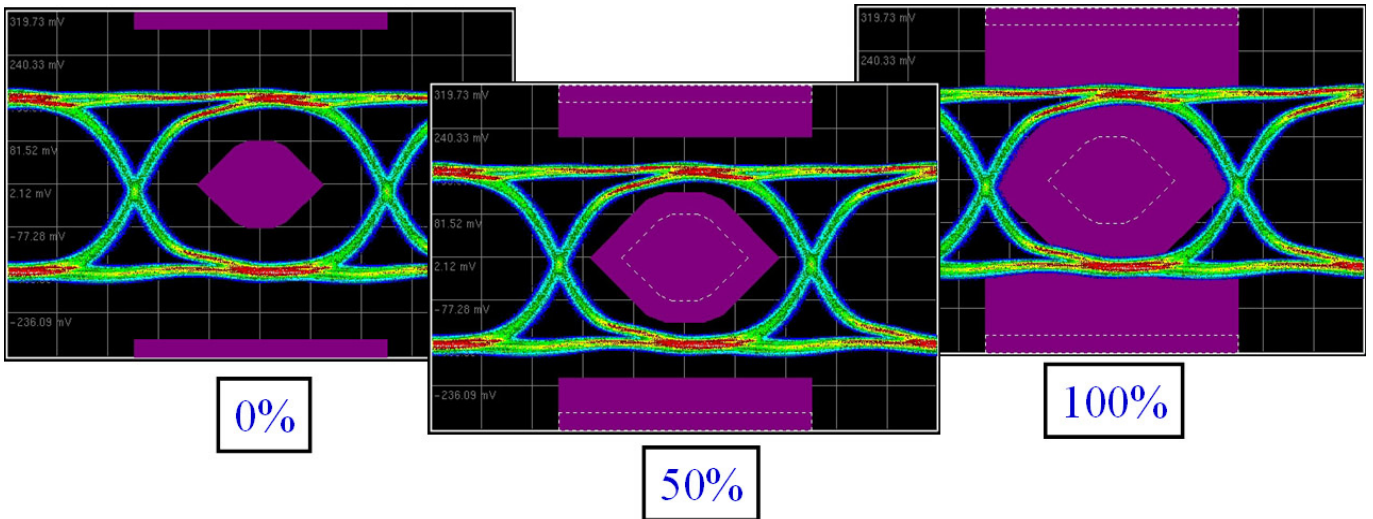

Figure 31. A typical mask margin test is shown for 0, 50, and 100 percent. The instrument automatically and linearly increases the mask line (shown by the dashed white line) until a failure is caused in the eye pattern measurement. The failed mask margin value represents with how much margin the current eye pattern measurement passes the compliance mask. This is a useful tool for monitoring the quality of the production process.

Extinction Ratio (ER). The extinction ratio measurement is a measurement that only applies to optical signals. The equation in Figure 32 shows the calculation of extinction ratio in dB as the ratio of one level to zero level from the eye pattern measurement. Like mask compliance testing, the standards specify this measurement with a 4th order Bessel-Thomson receiver response to simulate the far-end receiver response. In general, a higher level of ER produces a lower level of BER.

The extinction ratio measurement requires a very accurate measurement of the zero level since this value is in the denominator of the equation. For this reason, additional dark level calibrations are usually required to precisely measure the zero level for these calculations to produce accurate and repeatable results

$$ER(\text{dB}) = 10\log_{10} \frac{\text{One Level}}{\text{Zero Level}}$$

Figure 32. The equation for calculating extinction ratio (in dB) is shown. The small value of the zero level in the denominator requires great care in the eye pattern measurement to ensure accurate and repeatable calculations of extinction ratio. For this reason, a dark level calibration is usually performed prior to measurements to increase the precision of the zero level measurement.

Fourth-Order Bessel-Thomson Receiver Response. For optical mask compliance and extinction ratio measurements, the use of a filter ensures that the overall receiver frequency response conforms to the 4th order Bessel-Thomson response specified in the industry standards. Generally speaking, a separate filter is required for each data rate. For multiple data rates, a switched filter bank can be integrated into an instrument for convenience and consistency. This switched filter bank approach is offered in the BERTWave instrument and is ideally suited for the manufacturing production line environments. As an alternative, one can externally insert a filter into the measurement receiver path, which offers flexibility in troubleshooting scenarios where unfiltered measurements might reveal causes of eye closure. This external filter approach is provided in the Bit Master instrument and is ideally suited for measurements anytime, anywhere.

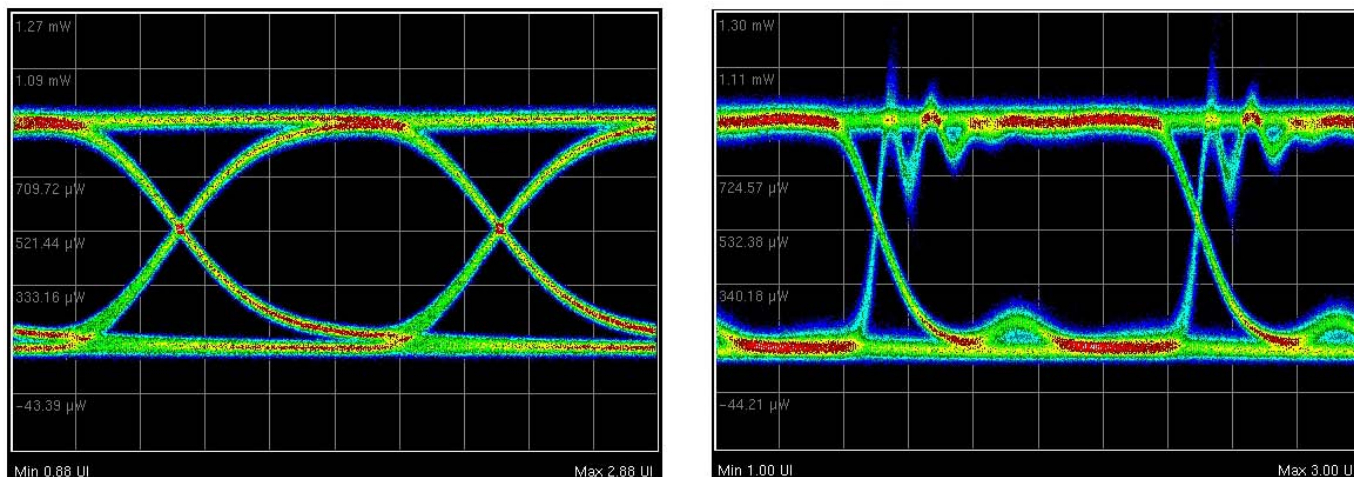

Figure 33. Mask compliance and extinction ratio measurements rely on data rate specific filters to ensure the overall response conforms to the 4th order Bessel-Thomson receiver characteristics specified in industry standards. An example of a filtered response at 2.5 Gbps is shown in this figure on the left. A corresponding unfiltered response is shown on the right and could help isolate causes of eye closure.

Summary

Understanding eye pattern measurements is important for any system manager or engineer dealing with 10 Gbps digital data transmission technology. The eye diagram is a powerful tool for assessing the quality of high-speed digital signals and can be used to calculate amplitude and time distortion parameters. Histograms support many of the amplitude and time distortion definitions in eye pattern measurements. Such terms can be extracted from the eye diagram using the Anritsu MP1026B Bit Master Eye Pattern Analyzer or the MP2100A BERTWave instrument.

For modern high-speed data systems, these instruments provide novel and powerful troubleshooting insights into signal and circuit impairments. The Bit Master and BERTWave, with their histogram algorithms, allow engineers to perform statistically-accurate measurements. When utilized with the Optical Module Converter option, these instruments can even perform these measurements when the-high speed data signals come from optical sources.

Anritsu

Anritsu Corporation

5-1-1 Onna, Atsugi-shi, Kanagawa, 243-8555 Japan

Phone: +81-46-223-1111

Fax: +81-46-296-1264

• U.S.A.

Anritsu Company

1155 East Collins Boulevard, Suite 100,
Richardson, Texas 75081 U.S.A.

Toll Free: 1-800-ANRITSU (267-4878)

Phone: +1-972-644-1777

Fax: +1-972-671-1877

• Canada

Anritsu Electronics Ltd.

700 Silver Seven Road, Suite 120, Kanata,
Ontario K2V 1C3, Canada

Phone: +1-613-591-2003

Fax: +1-613-591-1006

• Brazil

Anritsu Eletrônica Ltda.

Praca Amadeu Amaral, 27-1 Andar

01327-010 - Paraíso, São Paulo, Brazil

Phone: +55-11-3283-2511

Fax: +55-11-3288-6940

• Mexico

Anritsu Company, S.A. de C.V.

Av. Ejército Nacional No. 579 Piso 9, Col. Granada

11520 México, D.F., México

Phone: +52-55-1101-2370

Fax: +52-55-5254-3147

• U.K.

Anritsu EMEA Ltd.

200 Capability Green, Luton, Bedfordshire LU1 3LU, U.K.

Phone: +44-1582-433200

Fax: +44-1582-731303

• France

Anritsu S.A.

16/18 Avenue du Québec-SILIC 720

91961 COURTABOEUF CEDEX, France

Phone: +33-1-60-92-15-50

Fax: +33-1-64-46-10-65

• Germany

Anritsu GmbH

Nemetschek Haus, Konrad-Zuse-Platz 1

81829 München, Germany

Phone: +49 (0) 89 442308-0

Fax: +49 (0) 89 442308-55

• Italy

Anritsu S.p.A.

Via Elio Vittorini, 129, 00144 Roma, Italy

Phone: +39-06-509-9711

Fax: +39-06-502-2425

• Sweden

Anritsu AB

Borgarfjordsgatan 13, 164 40 Kista, Sweden

Phone: +46-8-534-707-00

Fax: +46-8-534-707-30

• Finland

Anritsu AB

Teknobulevardi 3-5, FI-01530 Vantaa, Finland

Phone: +358-20-741-8100

Fax: +358-20-741-8111

• Denmark

Anritsu A/S

Kirkebjerg Allé 90 DK-2605 Brøndby, Denmark

Phone: +45-72112200

Fax: +45-72112210

• Spain

Anritsu EMEA Ltd.

Oficina de Representación en España

Edificio Veganova

Avda de la Vega, nº 1 (edf 8, pl1, of 8)

28108 ALCOBENDAS - Madrid, Spain

Phone: +34-914905761

Fax: +34-914905762

• Russia

Anritsu EMEA Ltd.

Representation Office in Russia

Tverskaya str. 16/2, bld. 1, 7th floor.

Russia, 125009, Moscow

Phone: +7-495-363-1694

Fax: +7-495-935-8962

• United Arab Emirates

Anritsu EMEA Ltd.

Dubai Liaison Office

P O Box 500413 - Dubai Internet City

Al Thuraya Building, Tower 1, Suite 701, 7th Floor

Dubai, United Arab Emirates

Phone: +971-4-3670352

Fax: +971-4-3688460

• Singapore

Anritsu Pte. Ltd.

60 Alexandra Terrace, #02-08, The Comtech (Lobby A)

Singapore 118502

Phone: +65-6282-2400

Fax: +65-6282-2533

• India

Anritsu Pte. Ltd.

India Branch Office

3rd Floor, Shri Lakshminarayan Niwas,

#2726, 80 ft Road, HAL 3rd Stage, Bangalore - 560 075, India

Phone: +91-80-4058-1300

Fax: +91-80-4058-1301

• P. R. China (Hong Kong)

Anritsu Company Ltd.

Units 4 & 5, 28th Floor, Greenfield Tower, Concordia Plaza,

No. 1 Science Museum Road, Tsim Sha Tsui East,

Kowloon, Hong Kong, P.R. China

Phone: +852-2301-4980

Fax: +852-2301-3545

• P. R. China (Beijing)

Anritsu Company Ltd.

Beijing Representative Office

Room 1515, Beijing Fortune Building,

No. 5, Dong-San-Huan Bei Road,

Chao-Yang District, Beijing 100004, P.R. China

Phone: +86-10-6590-9230

Fax: +86-10-6590-9235

• Korea

Anritsu Corporation, Ltd.

8F Hyunjuk Bldg. 832-41, Yeoksam-Dong,

Kangnam-ku, Seoul, 135-080, Korea

Phone: +82-2-553-6603

Fax: +82-2-553-6604

• Australia

Anritsu Pty Ltd.

Unit 21/270 Ferntree Gully Road, Notting Hill

Victoria, 3168, Australia

Phone: +61-3-9558-8177

Fax: +61-3-9558-8255

• Taiwan

Anritsu Company Inc.

7F, No. 316, Sec. 1, Neihsu Rd., Taipei 114, Taiwan

Phone: +886-2-8751-1816

Fax: +886-2-8751-1817

